

Aura In-Line Turbo Mixed Flow Fan

220~240V Fan Installation and Operating Guide



- Aura In-Line Turbo 100B - 90001672
- Aura In-Line Turbo 100T - 90001673
- Aura In-Line Turbo 125B - 90001674
- Aura In-Line Turbo 125T - 90001675
- Aura In-Line Turbo 150B - 90001676
- Aura In-Line Turbo 150T - 90001677



Certificate No. EMS 58844 Certificate No. EM 00152
 SS EN 152 14001:2015 SS EN 152 14001:2015

Aura In-Line Turbo Fan Dimensions

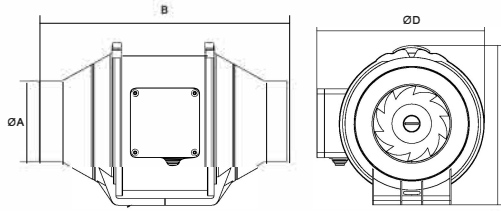

Model	A	B	C	D
100B/T	97	302	195	163
125B/T	123	257	195	163
150B/T	147	315	217	187

Fan Specification

Type	Open Air flow, m ³ /h	Current, Amps	Power, Watts	Noise level, db(A) @ 3m
100B/T	165/198	0.11/0.12	23/26	26/31
125B/T	248/284	0.13/0.14	28/33	26/31
150B/T	410/530	0.19/0.22	44/54	29/33

Range overview

Aura In-Line Turbo Mixed Flow fans are available in 3 model sizes with or without timer function and have 2 speeds.

These fans can be used as a simple extract or supply fan where high pressure and flow rates are required. They can be mounted in any plain. If mounted vertically a condensation trap should be fitted in the ducting to protect the fan unit. The range has been designed to accept standard ducting sizes. The main body of the fan (1) is detachable from the inlet and outlet spigots and mounting assembly via the 2 clamps (6).

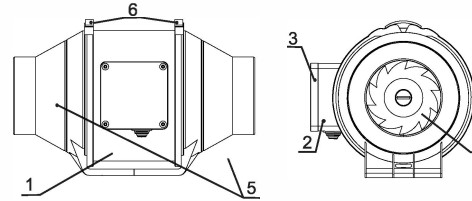

- 1 - Fan Body
- 2 - Terminal Box
- 3 - Terminal Box Cover
- 4 - Impeller
- 5 - Duct Connection Spigots
- 6 - Body Clamp Clips

Electrical installation

The Aura In-Line Turbo Mixed Flow range is IP44 rated and is suitable for mounting in Zone 2 in bathrooms, toilets, kitchens, utility rooms subject to not being in direct contact with water jets this must be installed with a 30mA RCD. The fan requires a 220~240V 50Hz single phase supply. Class II equipment. BS EN 60417. Fans should also be protected with an external 3A fuse (See diagram on page 5). Recommended cable sizes: Fixed flat wiring 2 core 1mm², 3 core 1/1.5mm². All electrical installation to be carried out by an approved electrician in accordance with Part "P" U.K. Building Regulations and to the latest IEC standards, or the appropriate regulations in the country of installation.

Important

The Aura In-Line Turbo Mixed Flow fan range is IP44 and complies with the requirements of the EU and UK norms and directives. Do not place the fan unit near direct heat sources, e.g. radiant heaters, or where temperatures can exceed 40°C (104°F). Precautions must be taken to avoid back flow of gases in rooms with open flue fuel burning appliances.

Electrical installation

100B, 125B, 150B

Min Speed Wiring

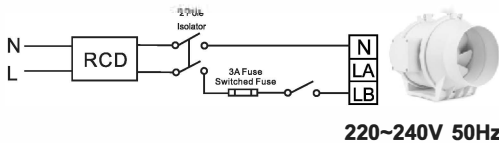

220~240V 50Hz

*When wiring min speed on 100B, 125B, remove safety strip, in front of terminal block LB connection.

Max Speed Wiring

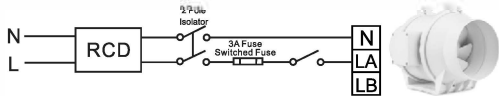

220~240V 50Hz

Terminal Block Guide Basic

- N Neutral
- LA Live High Speed
- LB Live Low Speed

Electrical installation

100T, 125T, 150T

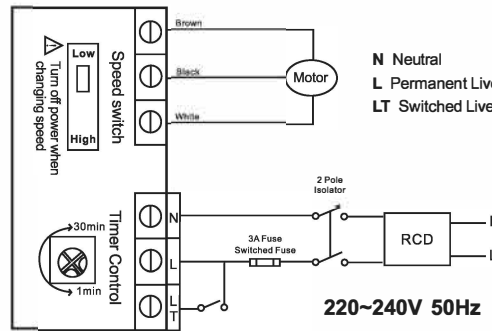

220~240V 50Hz

Speed Adjustment

Factory default speed is set to high. The speed can be adjusted to low by sliding the Speed switch to Low speed as shown in the above diagram.

Note, turn off power when changing speed.

Terminal Block Guide Timer

- N Neutral
- L Permanent Live
- LT Switched Live

Mechanical installation

Determine the orientation of the fan airflow direction by the use of the flow direction arrow shown on the fan body (See diagram on page 3 (1)). Remove the fan body by releasing the 2 body clamp clips (6). Using the mounting base as a guide, mark the fan mounting surface position. Suitable fixings should be selected to suit the mounting surface. Insert the fan body (1) and secure with the body by using the body clamp clips (6). Connect the appropriately sized ducting to the spigot ducts. Airflow Developments Ltd recommends that rigid ducting is used instead of flexible ducting, to keep system pressure to a minimum. This will help to ensure maximum performance of the installation.

Fan Timer Adjustment

The fan with timer function switches on when the voltage is supplied to the LT terminal via an external switch. After the voltage to the LT terminal is disconnected the fan continues to run for the set run on timer period, between 1 and 30 minutes. It is adjusted by turning the potentiometer (Timer Control) clockwise to increase and anti-clockwise to decrease. Care should be taken when adjusting timer control in order to not cause any damage to the potentiometer.

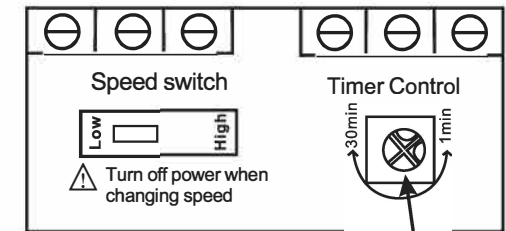

Potentiometer

Installation with flexible ducting

Where flexible ducting is used the diameter must be maintained with the minimum radius of a bend equal to the diameter of the ducting. It is good ventilation practice that the ducting is extended to 90% of its possible length in order to maintain the best possible airflow. Ensure that flexible duct connections are not over tightened to the fan outlet spigot. To maximise airflow rigid ducting should be used where possible. The fan and ducting should be installed in accordance with the requirements of the Domestic Ventilation Compliance Guide, part of the Building Regulations.

Page 9 of 16

Page 13 of 16

Recommended Best Practice

The Building Regulations 2010, Statutory Instrument Part 9, paragraph 42, imposes a requirement that testing and reporting of mechanical ventilation performance is conducted in accordance with an approved procedure. Compliance with this requirement by an assessed and registered 'Competent Person' should follow a 'Best Practice' process and adopt air flow measurement, Method A – The Unconditional Method – using a suitable UKAS certified measuring instrument. Generically referred to as a 'Zero Pressure Air Flow Meter' or 'Powered Flow Meter'. Further information on this method is detailed in NHBC Building Regulations Guidance Note G272a 10/13 and BSRIA 'A Guide to Measuring air flow rates' document BG46/2015

Maintenance

SAFETY FIRST: ALWAYS ISOLATE THE FAN UNIT FROM THE POWER SUPPLY BEFORE REMOVING THE COVER.

When installed according to these instructions the Aura In-Line Turbo range is completely safe. The materials used do not constitute a hazard.

Page 10 of 16

Page 14 of 16

Cleaning

External housing of the fan can be wiped with a damp cloth. Do not use household cleaners containing abrasives.

Internal parts can be cleaned with a dry soft brush or cloth. To gain access to the internal parts undo the body clamp clips (See diagram on page 3 (6)) and lift out the fan body. Care should be taken when cleaning the internal parts to prevent damage. When cleaning is complete replace the fan body and body clamp clips.

Note: Always isolate the fan when cleaning. Never clean any parts of the fan assembly by immersing in water or using a dishwasher.

Warning

This appliance can be used by children aged from 8 years and above and persons with reduced physical, sensory or mental capabilities or lack of experience and knowledge if they have been given supervision or instruction concerning use of the appliance in a safe way and understand the hazards involved. Children shall not play with the appliance. Cleaning and user maintenance shall not be made by children without supervision.

Page 11 of 16

Page 15 of 16

Warranty

Applicable to units installed and used in the United Kingdom. Airflow Developments Ltd guarantees the Aura In-Line Turbo for 2 YEARS from date of purchase against faulty material or workmanship. Warranty only covers the fan, not the re-installation of this if required. In the event of any defective parts being found, Airflow Developments Ltd reserve the right to repair or at our discretion replace without charge provided that the unit:

1. Has been installed and used in accordance with the fitting and wiring instructions supplied with each unit.
 2. Has not been connected to an unsuitable electrical supply.
 3. Has not been subjected to misuse, neglect or damage.
 4. Has not been modified or repaired by any person not authorised by Airflow Developments Ltd
 5. Has been installed in accordance with latest Building Regulations and IEEE wiring regulations by a recognised competent installer.
- Airflow Developments Ltd shall not be liable for any loss, injury or other consequential damage, in the event of a failure of the equipment or arising from, or in connection with, the equipment excepting only that nothing in this condition shall be construed as to exclude or restrict liability for negligence.

This warranty does not in any way affect any statutory or other consumer rights.

Page 12 of 16

AIRFLOW 

**UK
CA** 



Disposal

Do not dispose of with household waste.

Please recycle where facilities exist.

Check with your local authority for recycling advice.

UK Head-Office
AIRFLOW DEVELOPMENTS Limited
Aidelle House, Lancaster Road
Cresset Business Park
High Wycombe
Buckinghamshire
HP12 3DP
United Kingdom

Tel: +44 (0) 1494 525252
Fax: +44 (0) 1494461073
Email: info@airflow.com
Web: airflow.com

Czech Republic
AIRFLOW LUFTECHNIK GmbH
organizační složka Praha
Hořejská 520
128 00 Praha 2D
Czech Republic

Tel: +42 (0) 2 7477 2230
Fax: +42 (0) 2 747 7 2370
Email: info@airflow.cz
Web: airflow.cz

Germany
AIRFLOW LUFTECHNIK GmbH
Wülbernaacker 36
D-53359 Rheinbach
Germany

Tel: +49 (0) 222 692050
Fax: +49 (0) 222 69205 11
Email: info@airflow.de
Web: airflow.de

AIRFLOW DEVELOPMENTS LTD reserve the right in the interest of continuous development to alter any or all specifications without prior notice.

Page 16 of 16

80001230 Issue 1 05/22